

Class-X / Class-Y Capacitors

Class-X and Class-Y capacitors are used in AC line filtering in many electronic device applications. These safety capacitors are also known by other names, including EMI/RFI suppression capacitors and AC line filter safety capacitors. (EMI stands for electromagnetic interference and RFI stands for radio-frequency interference; RFI is simply higher-frequency EMI.) Class-X and Class-Y capacitors help to minimize the generation of EMI/RFI and the negative effects associated with received EMI/RFI.

In order for these capacitors to perform their EMI/RFI filtering tasks, they are directly connected to the AC power input, that is, the AC “line” and the AC “neutral” (see Figure below). And because of this direct connection to the AC voltage, the capacitors may be subjected to over voltage and/or voltage transients—lightning strikes, power surges. Thus, capacitor failure is a very real possibility.

When a Class-X capacitor, also referred to as an “across the line capacitor”—the capacitor placed between line and neutral—fails because of an over voltage event, it is likely to fail short. This failure, in turn, would cause an over current protective device, like a fuse or circuit breaker, to open. Therefore, a capacitor failing in this fashion would not cause any electrical shock hazards.

If a Class-Y capacitor, also known as the “line to ground capacitor” or “the line bypass capacitor”—the capacitor placed between line and ground—fails short, this could lead to a fatal electric shock due to the loss of the ground connection. Class-Y safety capacitors are designed to fail open. A failure will cause your electronic device to be subjected to the noise and interference that the capacitor would normally filter out, but at least there will be no fatal electric shock hazard.

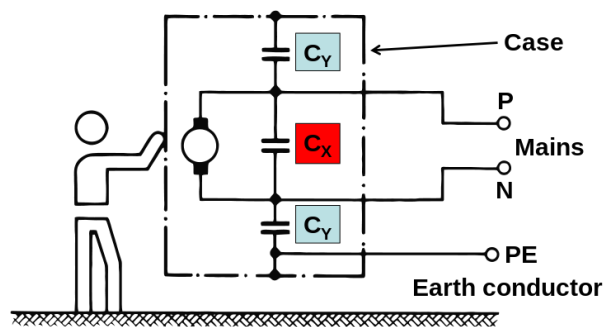

Appliance Class I: Case connected to electrical earth (ground)

Rating of Class-X and Class-Y Capacitors

Class-X and Class-Y capacitors are classified according to:

- their peak voltage/rated voltage and
- the peak impulse voltage that they can safely withstand.

Tables 1 and 2 below summarize the subclasses of Class-X and Class-Y capacitors.

Subclass (IEC 60384-14)	Peak Voltage Pulse (while in service)	Peak impulse before endurance test
X1	> 2.5 kV ≤4.0 kV	4 kV per C ≤ 1μF 4/√C kV per C > 1μF
X2	≤2.5 kV	2.5 kV per C ≤ 1μF 2.5/√C kV per C > 1μF
X3	≤1.2 kV	None

Table 1. Class-X subclass ratings*

Subclass (IEC 60384-14)	Rated Voltage	Peak impulse before endurance test
Y1	≤500 VAC	8 kV
Y2	150 VAC ≤ V < 300 VAC	5 kV
Y3	150 VAC ≤ V < 250 VAC	None
Y4	<150 VAC	2.5 kV

Table 2. Class-Y subclass ratings*

Deki offers a wide range of (RFI/EMI) noise suppression capacitors. Deki X2 capacitors are ENEC and UL approved. Deki Y2 capacitors are not UL/ENEC approved.

Series	Deki Series Code	Capacitance Value	Rated Voltage
Interference Suppression X-2 Capacitor	07, 20	0.01 to 2.2 μF	275 VAC, 305 VAC, 310V AC