

Capacitors for Fans



Electric motors are simple, reliable machines used in many appliances today. Single-phase induction motors, commonly found in ceiling fans, are robust and dependable. These motors require two fluxes to generate the torque needed for rotation. However, single-phase induction motors are not self-starting and need an auxiliary stator winding with an out-of-phase current (near 90°). Once started, the auxiliary winding is optional. In permanent-split capacitor motors, a capacitor is connected in series with the auxiliary winding during both starting and running.



Functional block diagram

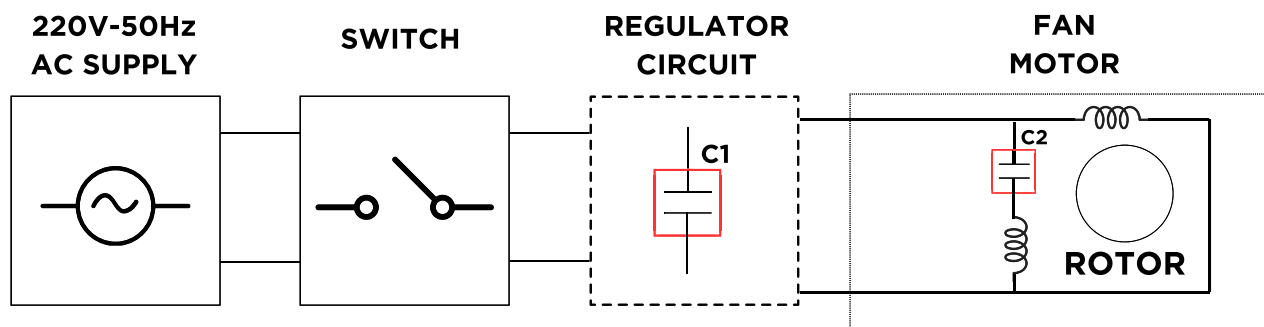

C1: Capacitor for Fan Regulator
C2: Capacitor for Fan Motor Run

Why Deki

One-Stop Shop
for All Film
Capacitor Needs

Comprehensive
DC & AC
Capacitor Solutions

Single-Digit
PPM Quality

Global Quality
Designed and
Made in India

Fast & Reliable
Delivery Prioritizes
Customer Deadlines

Capacitors for Fans

The Deki Range

Series No.	Capacitor Type	Function	Voltage range	Capacitance range
MPP and MPET Film Capacitors	Fan regulator	Provide voltage drop	250VAC	MPP: 1.8 μ F to 4.0 μ F MPET: 0.75 μ F to 6.0 μ F
123 - Rectangular Box 138 - Round Can	Motor run	Provide phase shift	440VAC	0.68 μ F to 4.0 μ F

For more details on the Deki range of capacitors for Fans, please scan the QR code.



Deki Capacitors: The Power Behind Efficient Fans



Deki Electronics Ltd

B-19 & 20 Sector 58, NOIDA 201 301, India.

+91 120 2585457, 2585458 • info@dekielectronics.com

www.dekielectronics.com